



# vmi fiorella

f500™ platformlift

The most innovative  
platform lift in the world.

imaginepossibilities 





VMI is proud to introduce the Fiorella F500™. Fiorella, based in Cervia, Italy, has produced platform lifts for the personal market for over 15 years and distributes its lifts in 47 different countries. The Fiorella design is uniquely attuned to the needs of platform lift users. Customer focus and engineering creativity allows Fiorella to offer platform lifts with features no one else can.

### fiorellaadvantages

- Visual and audible maintenance reminders
- Italian design that integrates beautifully with vehicle interiors and exteriors
- Cutting edge materials and engineering for compact size and low weight
- Simple installation takes three hours or less in most vehicles
- Detachable control unit plus right and left arm configurations for versatility
- Unique anti-crushing arm to stop the lift if any body part or object is in its path
- Three-year warranty on all parts plus a one-year warranty on labor
- Fully FMVSS compliant

### ease-of-usedesign

All lift functions can be controlled via the standard, jewel-like keychain remote or through an intuitive multi-language LCD interface. The LCD interface informs users when service is required or a maintenance interval is approaching, both with visual messages and audible reminders.

### integrateddesign

Until now, platform lifts sold in North America have been more industrial-looking. Fiorella's Italian design team has developed a platform lift that integrates beautifully with vehicle interiors. For customers who desire the highest level of visual integration, the external lift covers can be painted to match the vehicle exterior.

### modularity&versatility

The Fiorella F500™ comes in semi and automatic versions to meet the needs of both caregivers and independent drivers. The LCD control unit is detachable and can be located anywhere in the vehicle when space is at a premium. In addition, F500™ is offered in both right and left arm configurations, making it possible to optimize lift installation for specific applications and positions.



### Ford Transit Connect with VMI Fiorella F500™

The Fiorella F500™ can also be installed in the Mercedes-Benz Sprinter, GMC Savana, Ford E-Series and the Chevrolet Express.

### specifications

Semi-automatic and fully automatic versions available for caretakers or independent drivers. Note the following dimensions:

- Weight capacity: 500 lbs
- Usable platform width: 30"
- Usable platform length: 42"
- Unit weight: 285 lbs semi-automatic, 309 lbs fully automatic
- Lift travel: 29.1"
- Power supply: 12V
- Installed height: 40.9"
- Installed width (max.): 40.16" (F500™ sep. pump)
- Installed width (max.): 48.03" (F500™)
- Installed depth: 15.6"



● Multi-language LCD interface



● Remote control with sliding cover to protect controls with an elegant chrome finish



● Platform covers are color customizable



# Ford Transit Connect specifications

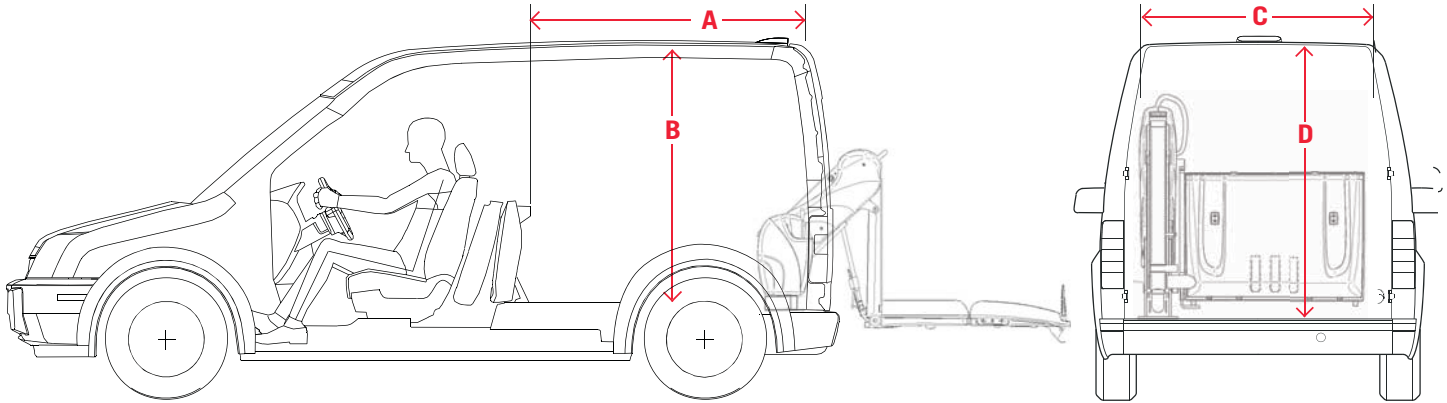

<b>A</b>	Length from folded second seat to back of van	59.2"
<b>B</b>	Maximum interior height	59.1"

<b>C</b>	Rear cargo door opening width	50.2"
<b>D</b>	Rear cargo door opening height	52.1"

## additional vehicles for installation:



Mercedes-Benz Sprinter



GMC Savana



Ford E-Series



Chevrolet Express

